

Safe, Stable and Efficient Operation of Centrifugal Compressors

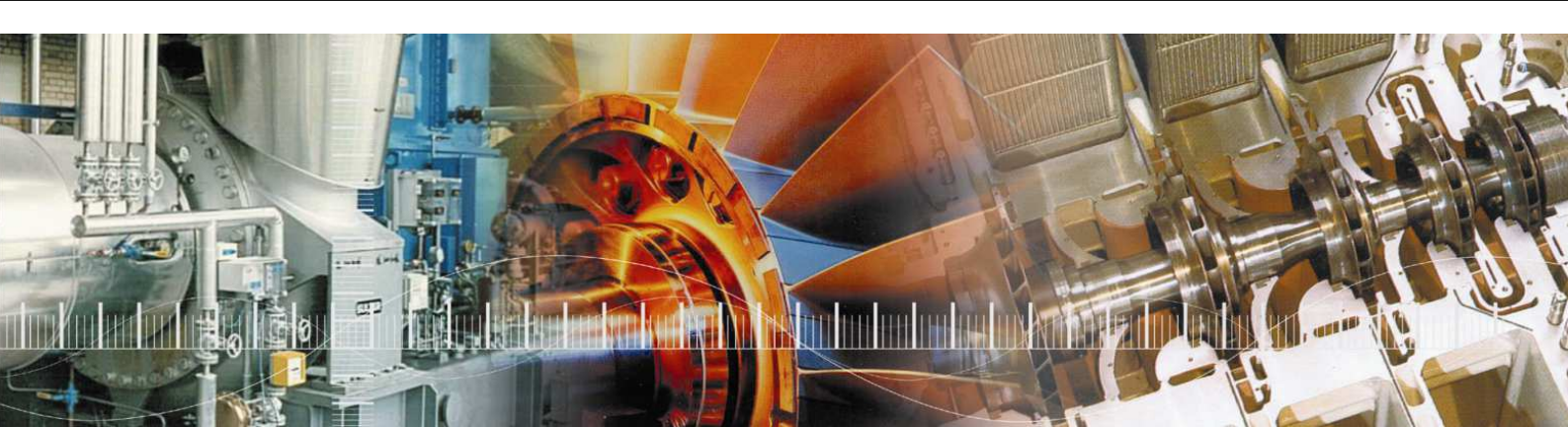

Anti-Surge Control by kmo turbo GmbH

Featuring Reverse-Flow Protection,
Multiple Surge Detection
and Patented Valve Control



Anti-Surge Control for Stable Operation

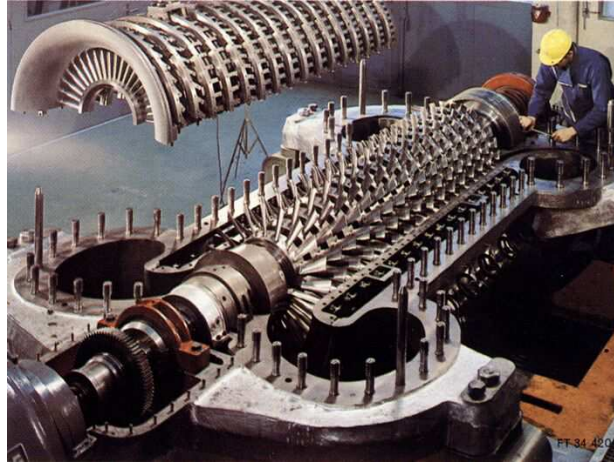

What is meant by "surging" with regard to a centrifugal compressor?

The characteristics map of a centrifugal compressor is divided into a stable and an unstable area by the surge line. "Surging" occurs when the operating point of the compressor is driven out of the stable area of the characteristics map, either due to a reduction of the flow rate or due to an increase of the discharge pressure. "Surging" is characterized by a cyclic flow and reverse flow of the compressed medium, accompanied by high levels of vibration, pressure surges and a rapid temperature increase within the compressor.

Persistent surging can lead to severe compressor damage. The flow malfunction can have disastrous effects on the downstream process.

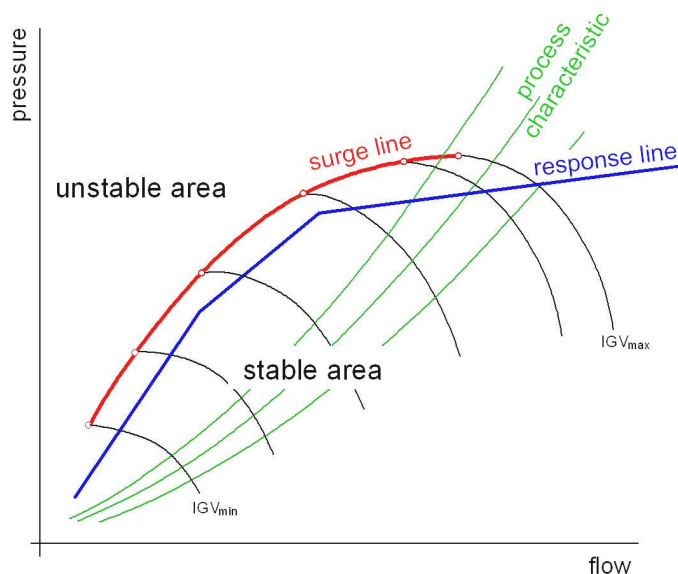

Protective Measures Against Surging

Compressors should be equipped with two independent systems, an anti-surge control and a reverse-flow protection.

The anti-surge control ensures that a stable operation is maintained. When the surge line is approached, the flow rate of the compressor is kept at the lowest possible value due to a controlled opening of a relief valve. If this control intervenes too late or not at all, the compressor will surge. Only then is the reverse-flow protection activated. Its task is to then prevent persistent surging by means of appropriate control interventions.

Why Both Anti-Surge Control AND Reverse-Flow Protection?

A reliable anti-surge control is dependent on several measuring signals. Due to the fact that these signals can be susceptible to errors, an anti-surge control alone is not considered to be reliable enough.

Most measuring errors are caused by leaky signal lines, by lines in which fluid has accumulated or by a drift of the zero point or measuring range.

The surge line itself is influenced by temperature, molecular weight and speed, but also by coating and wear of the blading. An anti-surge control cannot recognize all these influences.

The reliability of a reverse-flow protection is based on the fact that relative changes are monitored and not the absolute values. The **kmo** Reverse-Flow Protection ("**kmo** Surge Protector") simultaneously monitors up to 3 process values in order to monitor positive and negative change rates and MIN/MAX limit values.

Surge Protector for Reliable Protection

Anti-Surge Control by kmo turbo

The **kmo** Anti-Surge Control features numerous practical functions, which conventional control concepts don't provide. All of the functions are already programmed and only need to be parameterized:

- The controller runs permanently in automatic mode. Controller signal and manual signal are linked via a selection circuit: The valve can be opened manually at any time. Manual closing is only possible up until the response line of the controller is reached.
- Remote control can be performed either via bus, a 4...20mA signal or via binary contacts.
- A lag-free pressure limiting control is integrated.
- One of the outstanding functions is the minimization of the dead time, which is typical for pneumatic actuators, before the valve actually opens.
- Different control algorithms can be configured.
- DVP (Dynamic Valve Positioning): Driven via an event control, the expected valve position is set directly.
- Exact adaptation of the response line to the surge line course via a polygon of up to 10 lines. A temperature and/or speed correction is pre-configured.
- The function with which each actuator can be adjusted to ensure optimum control has proven most valuable.
- Partial opening is activated by the first surge impact. The compressor is protected; the downstream process can continue operation with a slightly reduced flow.
- Time-controlled full opening and/or machine shutdown in case of persistent surging.
- Event-controlled XP/TN changeover for stable operation in all operating phases.

Reverse-Flow Protection by kmo turbo

In addition to the reliable surge detection feature (3 signals, different criteria), the **kmo** Reverse-Flow Protection also offers a multi-level surge protection control (partial opening, full opening, shutdown) and a comprehensive range of diagnostic functions.

Comfortable Interpretation

A conventional surge protector is able to protect the compressor too. However, only the **kmo** Reverse-Flow Protection is able to provide important information, such as how often, at which time and during which operational phase the compressor surged. This information can be very useful toward providing fast and reliable conclusions on the cause of surging.

Diagnostic Functions:

- The date and time of each surge event is saved.
- Characteristic values are saved on each of the recent 100 surges:
 - process values 1 second before surging
 - triggering criterion
 - number of partial openings
- The number of surges is counted:
 - total number of surges
 - number of surges since the last machine start-up
- The total number of surges is monitored.
- The signal course of the last surge event remains saved and can be represented graphically and evaluated in detail.
- Both the number of machine start-ups and the number of operating hours are counted and monitored.

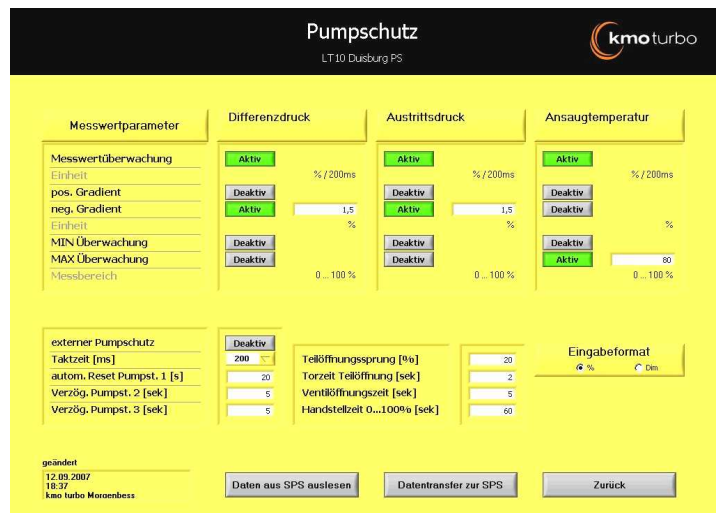
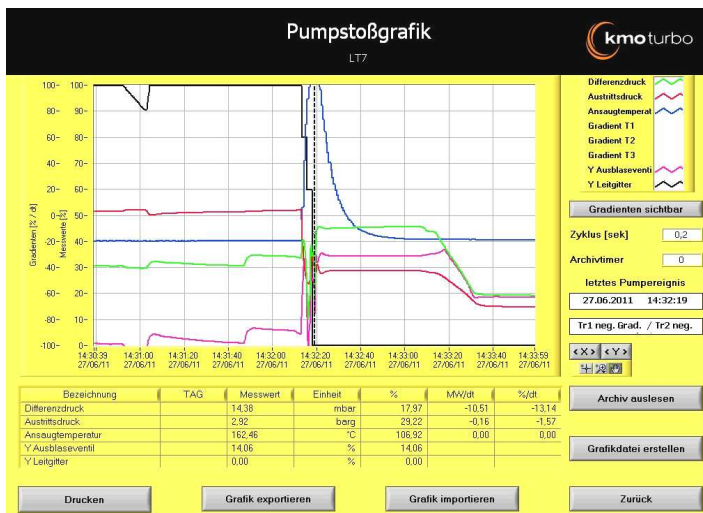

"kmo-surge" Software

The Perfect Solution

for Easy Operation and Staff Training

Hardware

The **kmo** Reverse-Flow Protection & Anti-Surge Control are available in SIEMENS S7, ABB Freelance and SCHNEIDER Quantum based versions.

Configuration, Parameterization & Simulation

The **kmo** unit for reverse-flow protection & anti-surge control is a stand-alone system, which only requires the support of a PC in order to perform configuration and set parameters at the first commissioning. With the aid of the "kmo-surge" application software (included within the scope of supply), the relevant values are simply entered into the self-explaining input masks.

An outstanding feature of this software is that the program also enables functional testing or even simulation of all of the control functions. No switches or mA sensors need to be connected. Therefore, the user is additionally provided with an ideal tool for training purposes.

Application / References

The **kmo** Reverse-Flow Protection & Anti-Surge Control system is suitable for all kinds of centrifugal compressors. Due to their compact design and flexible application potential, they are also particularly suitable for retrofitting in existing systems. Since 1995, **kmo turbo** systems have been used to equip numerous compressors produced by a wide range of manufacturers, such as Atlas Copco, Borsig, Demag, Escher Wyss, GHH, Ingersoll Rand, Joy, KKK, MAN Turbo, Nuovo Pignone, PGW, Siemens PGI and Sulzer.

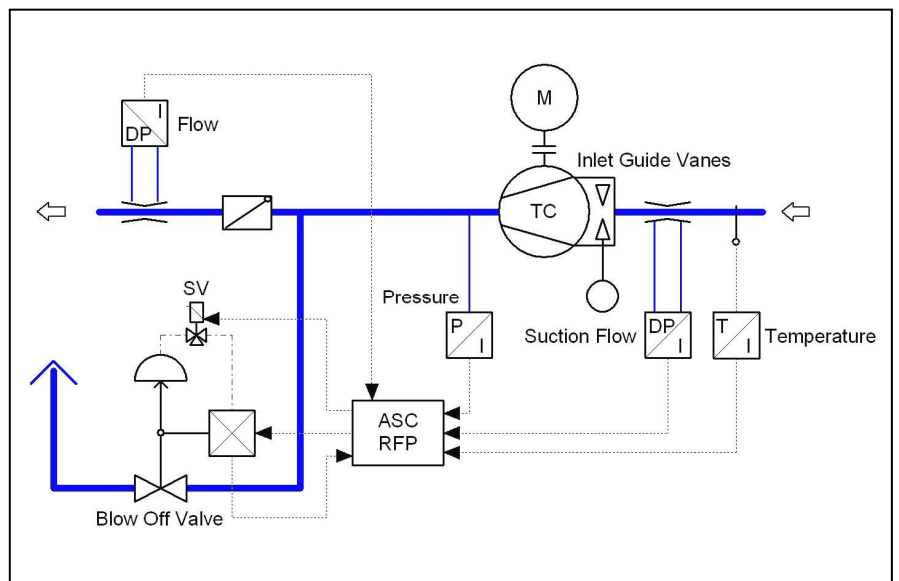

kmo turbo GmbH

Friedrichstr. 59
88045 Friedrichshafen
Germany

Phone: +49 7541 - 95289-0
Fax: +49 7541 - 95289-20
Mobile: +49 171 - 7432832

Internet: www.kmo-turbo.de

